

BSI 100 SERIES

The BSI 100 Series is a superior quality block and tackle balance take-out system designed for ease of installation, operation and removal. It is adaptable to most single and double hung aluminium or uPVC windows for either new or replacement applications.

Options:

- A variety of balances are available for specific sash weights and sizes.

Features:

- Fast, easy installation of balances - no tools required.
- Balances are engineered and manufactured for specific sash weights and sizes and require no adjusting during or after installation, significantly reducing labour costs.
- Balances are designed to travel full balance length allowing balance lengths to be the same for both upper and lower vents.

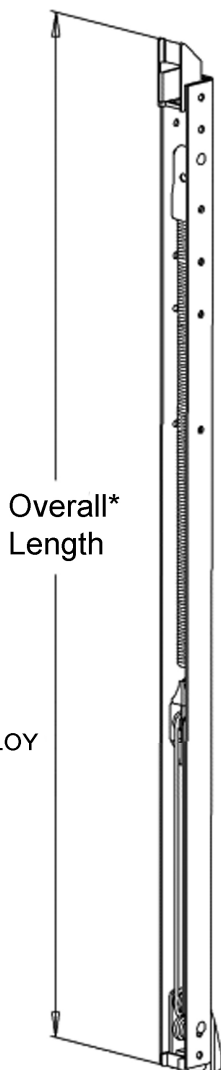

*See ASSA ABLOY Price Page for product details

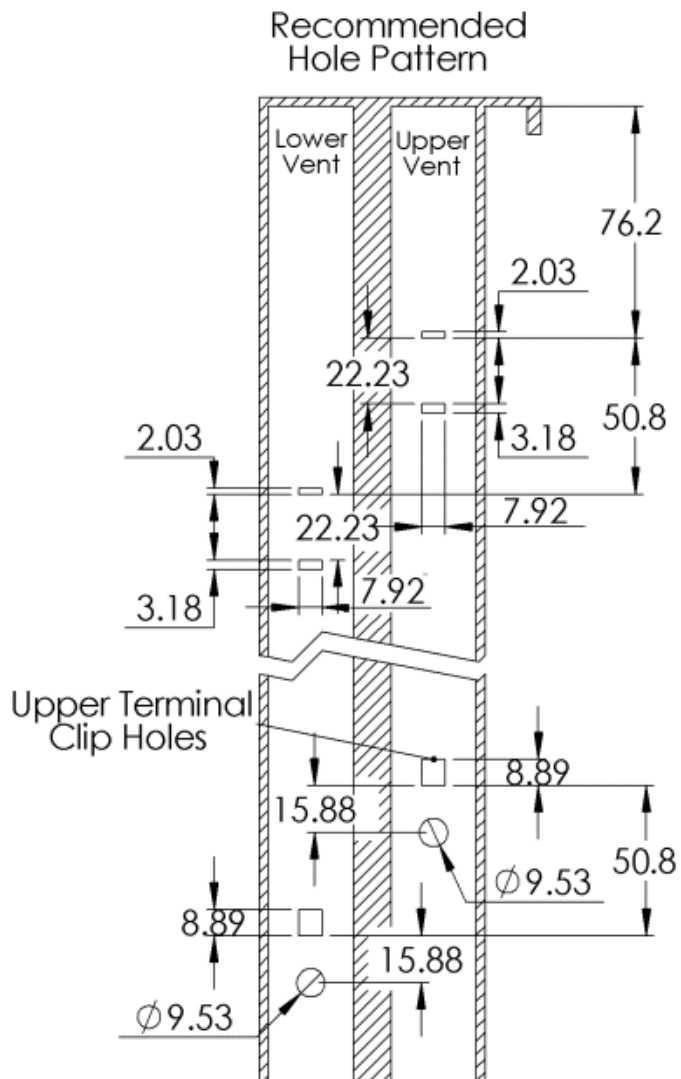

BSI 100 SERIES



APPLICATION GUIDE

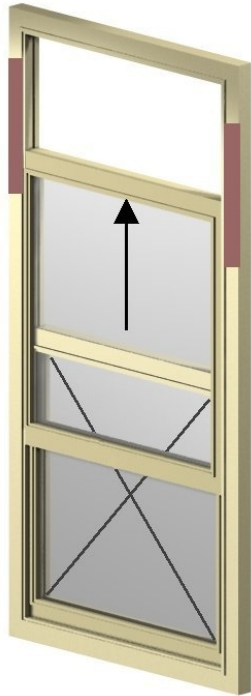

Single Hung



B1210: 13" (330mm) 1.4-2.7kg
B16DS: 17" (431mm) 11.4-15.9kg
B2090: 20" (533mm) 10.5-13.6kg
B2490: 24" (635mm) 10.9-13.6kg
B2840: 29" (737mm) 10.5-12.7kg
B3240: 33" (838mm) 10.5-12.7kg

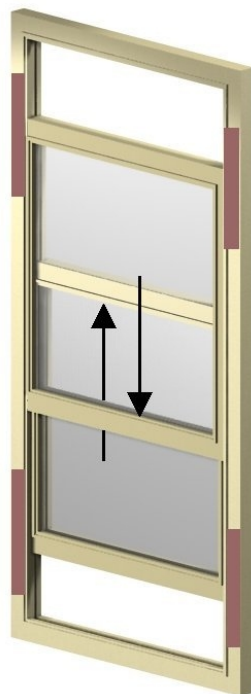

Double Hung



B1210: 13" (330mm) 1.4-2.7kg
B16DS: 17" (431mm) 11.4-15.9kg
B2090: 20" (533mm) 10.5-13.6kg
B2490: 24" (635mm) 10.9-13.6kg
B2840: 29" (737mm) 10.5-12.7kg
B3240: 33" (838mm) 10.5-12.7kg